

## **INTERACTION RULE GUIDANCE FOR CORROSION FEATURES REPORTED BY ILI**

**Lucinda Smart**  
Kiefner and Associates, Inc.  
Ames, Iowa, USA

**Yanping Li**  
Enbridge  
Edmonton, AB, Canada

**Bruce Nestleroth**  
Kiefner and Associates, Inc.  
Columbus, Ohio, USA

**Suzanne Ward**  
Enbridge  
Edmonton, AB, Canada

### **ABSTRACT**

Corrosion anomalies which reduce the strength of the pipeline must be mitigated appropriately. When corrosion defects have varying morphologies it is not always simple to determine the point at which the corrosion region becomes a safety concern, particularly for complex corrosion areas where multiple corrosion anomalies may interact with one another. Therefore, understanding how various anomalies may interact is important to determining the overall remaining strength of a pipeline under pressure. Many criteria for this spacing and how to apply the rules are recommended in the literature and have been studied either as the focus or periphery by several more, but no single criterion is provided as regulation. The task is left to the pipeline operator to choose the interaction rule for what is defined as ‘closely spaced corrosion.’ The method by which the failure pressure is calculated should be considered as varying levels of conservatism are inherent in these assessments.

Recommendations for interaction guidelines have been determined by either empirical or analytical approaches. The empirical approaches may be limited when an insufficient number and variety of pipes can be burst tested. Many analytical approaches are based upon relationships of remaining wall and simple corrosion morphologies which may not be applicable to real world corrosion. The source of the corrosion anomaly data is an important variable when selecting and applying interaction rules. In-line inspections (ILI) are the most common methods by which to obtain corrosion anomaly data, but each technology has an inherent measurement error and bias which should be considered. This paper will go into detail on each of the items discussed, present the current state of research into this subject in the industry, and will present a general

recommendation for selection of an interaction criterion for corrosion features reported by ILI.

### **INTRODUCTION**

The main topics to consider when selecting an interaction rule for the data reported by ILI are the failure pressure assessment methods, tool capabilities and general performance.

Multiple failure pressure assessment methods have been developed over the years for predicting the burst pressure of corroded pipe, such as; ASME B31G, Effective Area Methods, DNV RPF-101 and others, requiring; depth, length, and width discrimination of metal loss features as inputs. The identification and sizing of metal loss features may depend on their size and shape, as is the case for magnetic flux leakage (MFL) technology. There are no specifications for burst pressure accuracy by the ILI technologies since accuracy of burst pressure predictions can be affected by the presence of metal loss with dimensions outside the capability of ILI technology, such as the case with wide area metal loss for MFL tools. However, there is an expectation by both pipeline operators and regulators that burst pressure predictions are conservative compared with results from confirmatory direct examination reflecting the actual condition of corroded pipe. Therefore, comparison of burst pressure predictions from ILI data with calculated values from direct examination has become an important element of ILI performance validation in order to ensure pipeline safety.

In-line inspection results are used to identify and prioritize metal loss conditions for repair based on predicted failure pressure. Many factors involving the collection and processing of this data can affect the accuracy of the failure pressure predictions, most notably the precision of ILI in detecting all

anomalies and the determination of the shape and dimension of the corrosion, referred to as sizing. The levels of analyses, such as B31G, Modified B31G, Effective Area, or finite element analysis (FEA) require different levels of accuracy of the ILI data, with those requiring detailed dimensions requiring more accurate measurements.

## FAILURE PRESSURE PREDICTIONS

Failure pressures can be calculated using a variety of assessments, which include ASME B31G, the Modified B31G method, or an Effective Area method (i.e. Kiefner and Associates Pipe Assessment (KAPA) or RSTRENG). Each assessment criterion carries its own inherent conservatism, or may require more detailed measurements to produce accurate results. API 579 presents three levels of assessment for metal loss due to corrosion which vary in conservatism and complexity. A guide for these assessments is shown in Figure 1<sup>i</sup>. The corrosion assessment methods were all derived from the NG-18 “log-secant” equation which derives the relationship of a longitudinally-oriented defect and the failure stress in a pressurized cylinder. A Level 1 assessment is known as a two parameter assessment which uses an assumption of the resultant area based on a simple profile approximation using the maximum depth and overall length. Level 1 assessments include B31G, Modified B31G, or DNV RP-F101 for single anomalies.

A Level 1 assessment uses the dimensions of maximum anomaly depth and length to determine the area of the metal loss. A Level 2 assessment is the more detailed approach for complex defects, such as the Effective Area approach or DNV’s method for multiple defects. Level 2 determines the area affected by metal loss based on a river bottom depth profile. A river bottom depth profile captures the deepest point along the axial length of the area of metal loss. A Level 3 assessment requires the use of an FEA and is not currently practical for use with basic ILI data.

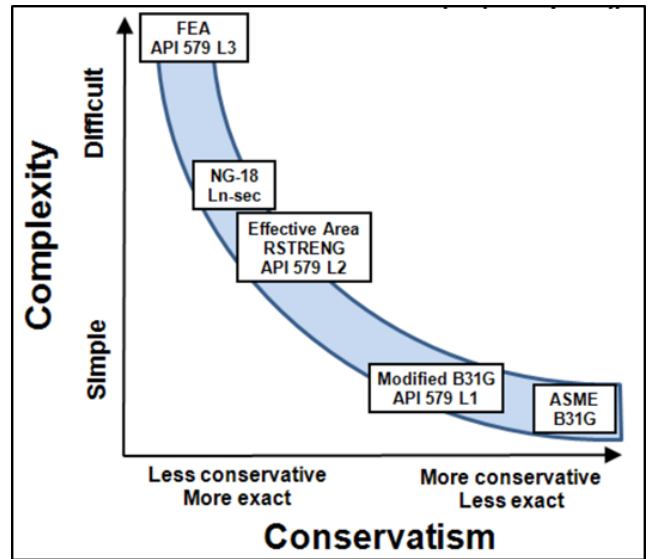


Figure 1. Relative Complexity of Failure Pressure Assessments and their Conservatism

## ILI DATA CONSIDERATIONS

Consideration of ILI tool performance is a regulatory requirement within many jurisdictions regulating liquid and gas pipelines. Current standard practice for ILI performance verification aims to determine if claimed ILI performance for depth predictions is acceptable using principles discussed in API 1163. This standard recommends verification of both anomaly detection capability and sizing accuracy. Most pipeline operators actively validate metal loss depth prediction performance for ILI tools using unity plots and other methods. However, detection of all interacting anomalies, such as smaller anomalies between larger ones, is a critical aspect of establishing appropriate interaction rules but the validation of probability of detection (POD) is not performed as often as validation of sizing accuracy. If the tool is not able to accurately detect certain corrosion morphologies and provide accurate sizes, this should be considered when applying conservatism to the assessment of the resultant data. Obtaining accurate quantities and sizes of anomalies which may interact are imperative for accurate failure pressure assessments. As an aside, when determining failure pressures, it is also important to address material properties. For example, the use of specified minimum yield strength (SMYS) adds an additional layer of conservatism on top of the interaction criteria. Most of the literature studies reviewed for this study did not incorporate material properties, so material property considerations were not included in this assessment.

The differences in the common ILI technologies used to report metal loss defects may contribute to the need for differing interaction rules for the data received from each tool type. MFL is the most commonly used assessment technique for both gas and liquid pipelines because of its ease of application, while ultrasonic testing (UT) is almost exclusively used in

liquid lines due to its need for a liquid couplant. MFL is an indirect measurement technique with the remaining wall thickness determined by a statistically derived function of signal amplitude, duration, and number of sensors responding, whereas UT is a direct measurement based on basic principles of physics. UT is able to get an accurate depth profile at discrete points for a metal loss pit or groups of pits and the Effective Area Methods can directly handle the interaction of neighboring pits. MFL generates an input for an Effective Area Methods assessment by defining length and maximum depth for each apex detected in a corrosion anomaly. For multiple metal loss calls in the MFL report in close proximity, these are then combined using interaction rules to conservatively assess the failure pressure. This is not the true “river bottom” used in many assessment methods since MFL may not detect or report every apex, but reports have shown it is a conservative approach. Vendors of tri-axial sensors and spiral MFL tools claim to offer better isolation of individual corrosion pits in a corrosion area and may provide better detection thresholds and sizing performances, but only depth and length information is provided for each apex in a corrosion area.

## MAGNETIC FLUX LEAKAGE TECHNOLOGY

For MFL systems, the source of inspection energy (permanent magnets) requires no outside source of energy during an inspection and the sensors and data recorders require relatively low electrical power to operate. The magnetic flux naturally enters the pipe and distributes evenly to produce a full volumetric inspection. The pipe wall is thinner at corrosion anomalies and the amount of magnetic flux that can be “conducted” by the pipe is reduced, an increased amount of flux leaks out of the steel pipe and is detected by hundreds of sensors spaced evenly around the circumference. The depth of corrosion anomalies is calculated from this local increase in magnetic flux and not directly measured. Since the amount of flux leakage is a function of many variables in addition to the amount of wall loss, the MFL wall loss measurement is more of an estimate than a precise number. MFL technology, first used in the 1960s, is a rugged measurement and can be designed to remain functional in an abusive pipeline environment for long distances at typical pipeline product flow speeds. The technology is quite mature with only small incremental improvement in recent years. Advances in MFL technology with more sensors are being used and recorded at finer increments have resulted in better quantification of the corrosion geometry. The corrosion profile of complex corrosion areas as determined by MFL is reasonably correlated with the Effective Area Method and interaction criteria described later in this document; however the MFL profile is not as precise and more conservative interaction criteria may be needed. Failure pressures may be able to be calculated with reasonable accuracy related to that of field assessments, however, as shown in recent research.<sup>ii</sup>

In an attempt to assess a large area of corrosion from MFL results, burst pressures are calculated from the dimensions and locations of abstract “boxes” meant to approximate the area of an actual corrosion profile. Each box is an isolated MFL response that contains depth and length information, which can be a single continuous corrosion anomaly, but can also be a group of pits that MFL analysis could not isolate. The derivation of these boxes, and interacting boxes forming clusters, depends on ILI vendor proprietary signal processing algorithms, and their correlation with actual metal loss features located on a pipe during direct examination has presented challenges for performance evaluation.

The basic principles and complexity of flaw interaction for a pipe with a wall thickness ( $t$ ) of 0.344 inch are demonstrated in Figure 2 and Figure 3.<sup>iii</sup> In Figure 2(a), the MFL color image of a pair of  $3t$  anomalies separated circumferentially by  $3t$  appears to be one wider anomaly. This effect is called circumferential blooming. In Figure 2(b), the MFL false color image of a pair of  $3t$  anomalies separated axially by  $3t$  appears to be two distinct anomalies. The spreading of the signal in the circumferential direction leads to a potential conclusion that interaction criterion in the circumferential direction may not need to be as conservative as that in the axial direction. The separation of individual pits can be improved by using sensors that measure all three components of the magnetic field, referred to as tri-axial sensors. The interaction rules for single component MFL sensors may have to be more conservative than results from MFL tools with tri-axial sensors.

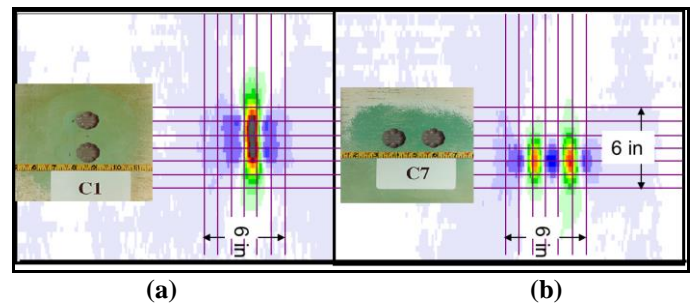


Figure 2. Complexity of MFL Flaw Interaction

Figure 3 shows the additional complexity of larger metal loss anomalies shadowing smaller metal loss. In the image, a pair of  $3t$  anomalies separated axially by  $3t$  appears to have a white area between them which is the same appearance as the full wall thickness; however, the wall thickness is reduced by 20% in that area. This is called axial shadowing. A misinterpretation of this image could lead to an under prediction of failure pressure if a profile technique is used. With many possible corrosion morphologies, this interpretation challenge can lead to more conservative interaction rules.

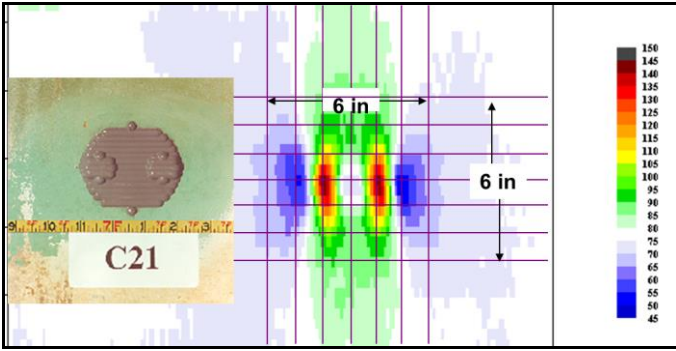


Figure 3. Complexity of Larger Metal Loss Anomalies

MFL signals are converted to metal loss depth measurements by analysis software algorithms. For most MFL ILI technologies, signals from individual corrosion anomalies above a prescribed level or discernable by the software algorithms are approximated as rectangular “boxes” with associated depth, length, and width dimensions and delivered as such to the customer for integrity evaluation. Figure 4 shows examples of wide-area complex corrosion with MFL signals where some of the flux leakage signals may not have been boxed appropriately. When boxes are missed by the software, no ILI features are identified for severity evaluating or reporting.

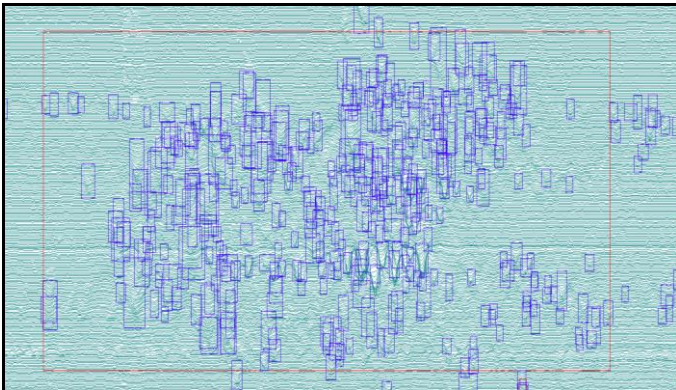


Figure 4. Complex, Wide-area Corrosion

A reporting threshold is commonly applied due to the inherent limitations of ILI to accurately and reliably report features with shallow depth. The metal loss anomalies of most importance for integrity decisions are typically those above a prescribed depth or overall size. Therefore, a reporting threshold allows the data to be filtered to remove some of the noise of the potentially less accurate data while still retaining the metal loss anomalies which are important for severity evaluation. Figure 5 provides a visual representation of the reporting threshold and its impact on anomaly analysis. In Figure 5(a) a 10% wall thickness (t) reporting threshold has been applied. This produces two separate anomalies reported for evaluation. In Figure 5(b), there is no reporting threshold,

leading to the 8% t signal boxed. This produces one larger ILI anomaly for severity evaluation.

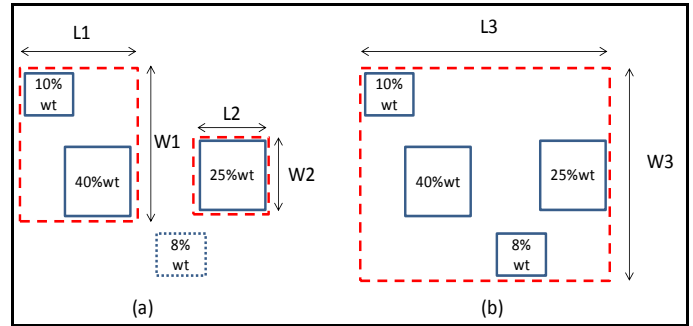


Figure 5. MFL Analysis Reporting Threshold for the Same Available Data: (a) 10% WT Depth Threshold (Produces 2 Individual Clusters); (b) 0% WT Depth Threshold (Produces a Larger Interacted Cluster)

### ULTRASONIC TECHNOLOGY

Ultrasonic technology (UT) measures corrosion depth directly using a simple distance (wall thickness) equals velocity multiplied by time formula. Detection threshold and depth sizing accuracy are specified in units of distance, not wall thickness. Specifications based on wall thickness are illustrated in Table 1 for selected common wall thickness. The detection threshold is different for OD and ID corrosion, and can be quite large as a percentage of wall thickness for thinner pipe as compared to the 10% detection threshold specified by most MFL systems. The claimed sizing accuracy of UT is better than MFL for all wall thickness presented. UT has the ability to measure corrosion cells in discrete increments on the order of 3mm (1.2 inches), a better measure of the river bottom than MFL can provide. The issues of circumferential blooming and axial shadowing associated with MFL analysis are not a problem for UT ILI tools. However, these tools only work with a liquid couplant.

Table 1. Example of Ultrasonic Sizing and Detection Specifications

	UT Spec		Percentage for Common Wall Thicknesses (in) for which Sizing Accuracy is Valid					
	mm	in	0.188	0.219	0.25	0.281	0.312	0.375
Detection Threshold ID ML	0.8	0.031	17%	14%	13%	11%	10%	8%
Detection Threshold OD ML	1.2	0.047	25%	22%	19%	17%	15%	13%
Sizing Accuracy	0.4	0.016	8%	7%	6%	6%	5%	4%

### INDUSTRY STANDARD RECOMMENDATIONS

Section 1.12 from ASME B31G-2012<sup>iv</sup> discusses flaw interaction and flaws which are closely spaced axially or circumferentially may interact to produce a lower calculated

failure pressure than if these flaws are addressed individually. It states the interaction guidelines of flaws spaced longitudinally and transversely within a distance of three times that wall thickness (3t), shown in Figure 6. The 3t by 3t rule was determined empirically through limited testing and analysis. Additional research has shown the applications of the aforementioned interaction criteria may be non-conservative for corrosion morphologies which are difficult to accurately detect and size by ILI. The Pipeline Operators Forum document recommends using this method as a default, but also lists many other alternatives for both applying interaction rules and the methods by which to assess the failure pressure.<sup>v</sup>

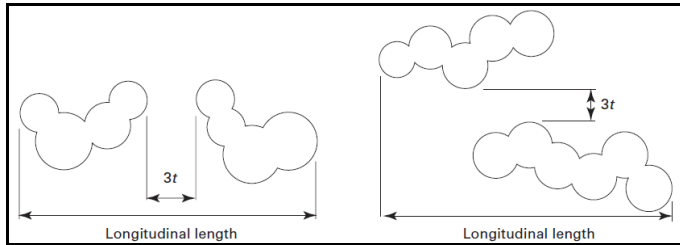


Figure 6. Interacting Flaw Defined by B31G

The DNVGL RP-F101 method<sup>vi</sup> assesses areas of metal loss based on both wall thickness and pipe diameter and was developed primarily using stress and strain properties of the remaining wall. The minimum spacing allowed between flaws in the circumferential direction, presented in degrees, is

$$\phi > 360 \sqrt{\frac{wt}{D}}$$

The minimum spacing allowed between flaws in

the axial direction is  $s > 2\sqrt{D(wt)}$  shown in Figure 7. See Table 2 for some examples of how this converts into wall thickness for sample pipe sizes.

Table 2. DNV Interaction Distance Conversions

Diameter	WT	Circumferential Spacing			Axial Spacing	
		Angle $\phi$	Distance	in WT	Distance	in WT
(inches)	(inches)	(degrees)	(inches)	(T)	(inches)	(T)
24	0.344	43	9.0	26	5.7	17
24	0.25	37	7.7	31	4.9	19
8	0.25	64	4.4	18	2.8	11
8	0.188	55	3.9	20	2.5	13

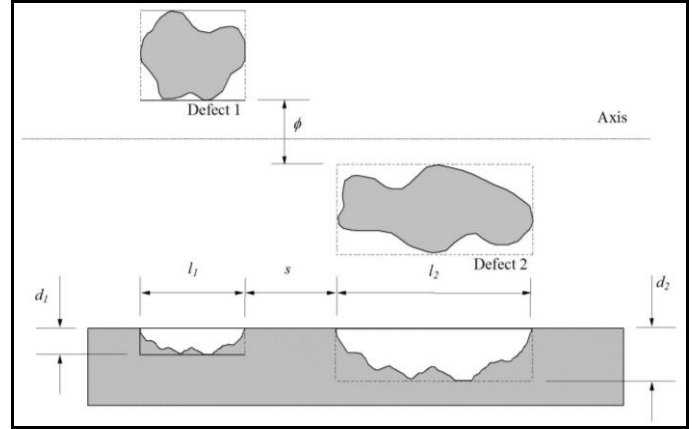


Figure 7. Interacting Flaw Defined by DNVGL RP-F101

CSA Z662-15<sup>vii</sup> states that the longitudinal length and the maximum depth of a corroded area should be determined one of two ways, the first being prescriptive, the second being derived by a defensible engineering assessment. The first is determined by a variable “G”, which is defined as the smallest distance in any direction between the two areas of metal loss. If that distance G is less than the longitudinal length of the smallest area, then they interact. A diagram of this interaction rule is shown in Figure 8. The application of this interaction criterion is complex and difficult even when applied in field to actual corrosion features.

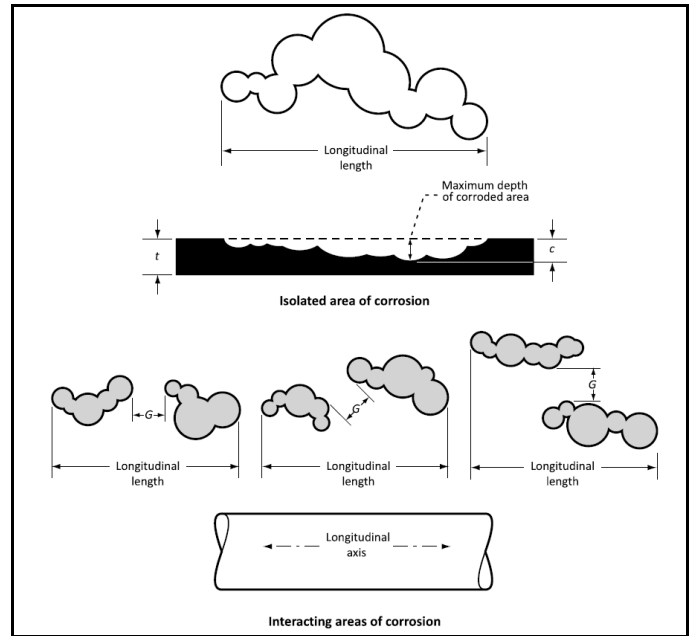


Figure 8. Interacting Flaw Defined by CSA Z662-15

In the BS7910 method<sup>viii</sup>, the sizes of the metal loss areas are compared using an “s” distance apart and a flaw length “2c”. Interaction of shallow flaws with a ratio of depth to length of less than one is only considered when the flaws are touching, shown in Figure 9. The formulas were derived based on stress

failure principles, and determining the limit for yielding of the material itself.

The API RP 579<sup>ix</sup> fitness for service recommended practice offers an interaction rule which looks at flaws which interact with its neighbor if a box of dimensions 2s and 2c drawn around the feature captures any of the area of the neighboring defect. The diagram in Figure 10 illustrates how to apply this method.

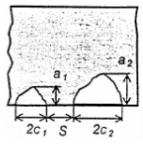
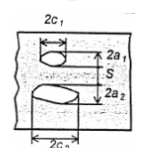
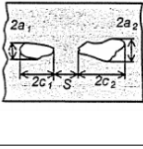
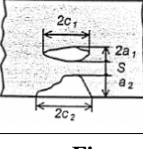
CASE	COMBINATION CRITERIA	EFFECTIVE DEFECT DIMENSIONS
	<p>For <math>a_1/c_1</math> or <math>a_2/c_2 &gt; 1</math>:  <math>S \leq \min(2c_1, 2c_2)</math> OR  <math>S \leq \max(0.5a_1, 0.5a_2)</math></p> <p>else:  <math>S \leq \max(0.5a_1, 0.5a_2)</math></p>	<p><math>a = \max(a_1, a_2)</math>  <math>2c = 2c_1 + s + 2c_2</math></p>
	<p><math>S \leq a_1 + a_2</math></p>	<p><math>2c = \max(2c_1, 2c_2)</math>  <math>2a = 2a_1 + s + 2a_2</math></p>
	<p>For <math>a_1/c_1</math> or <math>a_2/c_2 &gt; 1</math>:  <math>S \leq \min(2c_1, 2c_2)</math> OR  <math>S \leq \max(a_1, a_2)</math></p> <p>else:  <math>S \leq \max(a_1, a_2)</math></p>	<p><math>2a = \max(2a_1, 2a_2)</math>  <math>2c = 2c_1 + s + 2c_2</math></p>
	<p><math>S \leq \frac{2a_1 + a_2}{2}</math></p>	<p><math>2c = \max(2c_1, 2c_2)</math>  <math>a = 2a_1 + s + a_2</math></p>

Figure 9. Interacting Flaws Defined by BS7910

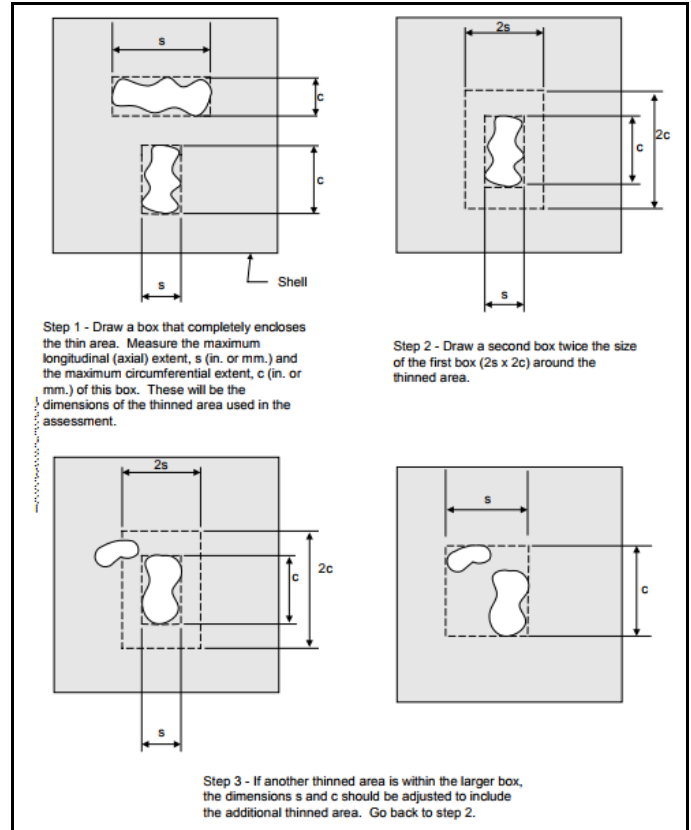


Figure 10. Interacting Flaw Defined by API RP 579

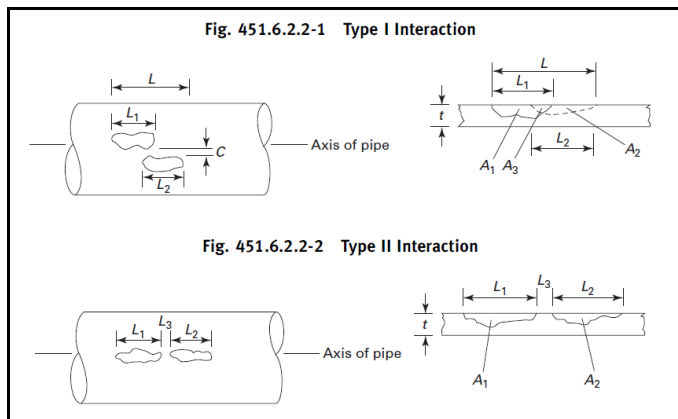
## INTERACTION CRITERIA RESEARCH

Standards were adopted to guide the determination of when multiple areas of corrosion present on a pipeline cause a reduction in pressure. Two types of interacting flaws are defined by ASME B31.4<sup>x</sup> shown in Figure 11. The studies summarized in the following section are those which are prominent in the industry for assessing what interaction criteria are recommended. Several suggest the distances presented by the models in ASME B31G and CSA Z662-15 appear to be non-conservative. Note both empirical and FEA based studies have the advantage of knowing the exact geometry of the corrosion. As discussed previously, ILI tools have inherent measurement error which is not taken into account in these studies, but should be considered in future studies. A sensitivity analysis could be performed to compare the performance of an interaction rule applied on ILI to that of the in-ditch inspections to observe how corrosion morphologies and ILI performance may affect the resultant calculated failure pressures. The following section will discuss what each recommends and briefly how they came to that conclusion. A summary of the interaction rules for each is presented in Table 3.

**Table 3. Summary of Interaction Rules of Industry Studies**

Author Names	Year Published	Empirical/FEA Method	Circumferential Maximum Distance	Axial Maximum Distance
Kiefner, J.F.	1969	Empirical	6t	1 inch
Coulson, K.E.W.	1990	Empirical	Width of narrowest flaw	Length of shortest flaw
Chauhan, V., Grant, R.	2002	FEA	6t	6t
Cunha, S.B.	2008	FEA	$(\pi)/(4*r*d)$	$<1/2*r$
Chandra, B., Mondal, B.C., Dhar, A.S.	2016	FEA	$1.5\sqrt{(Dt)}$	8t

In early research<sup>xi</sup>, the Battelle Memorial Institute addressed the problem of interacting flaws. The failure behavior of metal loss areas was investigated empirically using full-scale testing with machined features, two of which were longitudinal grooves and two were pits. Ultimately 12 full scale tests were performed which laid the foundation for the interaction programs performed thereafter. The two main types of interaction identified by ASME B31.4-2016<sup>xii</sup> are shown in Figure 11. Within the Type I scenario where flaws are separated circumferentially but overlap in the axial direction when cast on a single plane, experiments showed that a circumferential spacing of less than six times the wall thickness of the pipe would mean those features interact as one anomaly for a burst pressure calculation. For a Type II scenario where flaws are separated axially but overlap circumferentially when cast on a single plane, experiments showed an axial spacing of one inch or less, results in flaws interacting and reducing burst pressures.



**Figure 11. Type I and Type II Interaction Diagrams from B31.4-2016**

A few decades after the Battelle research was presented, a research study was performed by the Nova Corporation of Alberta<sup>xiii</sup>, which also addressed the problem of multiple corrosion areas with flaws longer than the diameter of the pipe,

spirally oriented features, and interacting features. Thirteen full scale tests were performed, and all flaws were manufactured as rectangular features at least one-inch in width, with a depth of 40% t to represent flaws of significant depth. The results of the burst testing found that interaction is a complex problem and depends on the flaw’s relative length, width, depth, and separation. Flaws may interact in the axial direction if the separation between them is less than or equal to the length of the shortest. Flaws may interact in the circumferential direction if the separation between them is less than or equal to the width of the most narrow flaw. For spiral flaws, interaction occurs if the separation in the spiral direction is less than the length of the shortest flaws, and those that are separated by at least 12 inches are not expected to interact. One of the main conclusions of the study is that the work is not as straightforward as originally anticipated and more research would need to be performed to better understand the behavior of metal loss areas to eliminate overly conservative safety factors. This method is similar to CSA Z662-15 in that the dimensions of the reported anomaly determine the interaction criteria.

A research project by Advantica through the Pipeline Research Council International (PRCI)<sup>xiv</sup> used an analytical, FEA method for determining an appropriate interaction criterion. Pairs of adjacent flaws were evaluated for pit-groove, pit-pit, and groove-groove profiles. Interaction criteria used varying interactions between 1t and 6t and found that the change in resultant burst pressures was negligible for small diameter (<2t) pits and more significant for larger diameter (>8t) pits, but still less than a 10% change. The observations from this study found that the interaction of groove-groove flaws separated axially can be significant, while the interaction of circumferentially spaced flaws is negligible. The final recommendation suggested that the interaction criteria presented by PRCI guidelines, DNV RP-F101, and BS7910 should be more relaxed. They also recommend a full scale burst test study be performed as a follow up to the analytical assessments.

An analytical study<sup>xv</sup> performed by Petrobras Transporte SA – Transpetro used hypothesized flaws and observed the stress and strain perturbation from the corroded area to the intact portion of the pipe. The presence of stress and strain fields of the intact portion of the pipe show the fields of defects may interact to produce a remaining strength of flaw that is lower than that of the single anomalies. The interaction method suggests performing an initial screening test of flaws which may interact, and if they do, then perform a more accurate verification of the dimensions of the flaws. The initial screening suggests flaws interact axially if they are spaced less than half of the pipe radius (r) apart. In the circumferential direction, flaws interact with a spacing of less than  $(\pi)/4*r*d$  from the flaw boundary, where d is the flaw depth. The more precise equations for limiting interaction distance for axis-symmetric and narrow flaws are more complex and follow a flowchart to determine how to assess them. The results of this study assisted in supporting the concept that the interaction criteria presented

by ASME B31G and CSA Z662 may be non-conservative. However, it was also performed on an analytical basis with justification using FEA models with assumptions of uniform strain throughout the metal loss area, and has not yet been substantiated with real corrosion and burst testing pressure validation results.

A study in the early 2010s out of the Memorial University of Newfoundland<sup>xvi</sup> concluded that ASME B31G and CSA Z662 methods are non-conservative. They studied the effect of corrosion with rounded edges versus those with sharp edges and found the difference was not significant. FEA was used to determine the burst pressure values for comparison. This study revealed that a limiting distance in the axial direction was  $8t$  and circumferentially was  $1.5\sqrt{Dt}$ , where  $D$  is the pipe diameter and  $t$  is the wall thickness. This interaction rule is similar to the one given by DNV-RP-F101 code, and was developed using nine different finite element models with various pipe dimensions and corrosion geometries.

A recent study within Kiefner<sup>xvii</sup> determined that  $3t$  by  $3t$  for MFL ILI calls is non-conservative for most corrosion morphologies. This study compared the use of interacting MFL ILI data with in-ditch interacted data. This approach provides a method by which the tool performance of ILI and type of corrosion assessed may affect how to apply interaction criteria. Shallow (defined as majority of metal loss at less than 50%  $t$ ) and sparsely populated areas of metal loss resulted in the  $3t$  by  $3t$  criterion being acceptable, as the structural integrity of the remaining wall is not affected across the region between the corrosion. For a region of more densely populated corrosion, a comparison of various interaction rules of  $3t$  by  $3t$ ,  $6t$  by  $6t$ , and  $12t$  by  $12t$  showed that there was less conservatism in the  $3t$  by  $3t$  rule, but the  $6t$  by  $6t$  to  $12t$  by  $12t$  did not significantly change. However, this corrosion was all shallow (less than 50%  $t$ ). If this type of corrosion was more widely distributed across a larger region of the pipe, the burst pressure results would likely change, and could require a larger interaction criterion.

## SUMMARY

The literature review showed that assessing the remaining strength of pipe with multiple corrosion anomalies has many approaches with varying degrees of conservatism. The development of these interaction criteria is based either on empirical assessment of the pipeline and actual burst pressure testing, or FEA of primarily rectangular shaped or idealized flaws. Both have limitations in their development. The studies based on empirical results may be limited since a representative population or various types of corrosion morphologies could not be practically studied. FEA studies are limited by the small number of geometries assessed and the use of precisely known dimensions with no consideration for measurement error.

The issue is further complicated by the error of the ILI data which would be used in the application of these interaction criteria. Even after applying a conservative interaction criteria, a significant source of non-conservative results are corrosion

anomalies that are not reported by ILI. In addition to verifying tool depth sizing capability, performing an analysis of the ILI tool performance with regards to probability of detection (POD) before applying an interaction criterion is recommended. Similarly, depth threshold for reporting should be considered as well. The pipe body wall has the opportunity to fail either due to a membrane thinning or a bulging of the remaining wall between the areas of corrosion. If the ILI tool does not detect or does not report shallow areas of corrosion, this may adversely affect the resultant burst pressures.

In determining how to apply an interaction rule, the method by which the failure pressure is calculated was considered. API 579 categorizes assessment approaches into three levels. The use of a Level 3 FEA method, the most rigorous approach, is largely impractical using ILI data. Measurements are not precise enough to do this level of analysis, and therefore Level 3 analyses are not generally considered with the current ILI technologies.

The use of a Level 1 method, either B31G or Modified B31G, is most appropriate for MFL technologies if a river bottom profile cannot be obtained through the vendor. The application of the recommended interaction rule mainly applies to Level 1 failure pressure methods, where true ILI tool performance with regards to POD or POI may be unknown, but may be compensated for by an appropriate interaction rule. For UT ILI data on heavy wall pipe of 12mm (0.473 inches) wall thickness or greater, sensor circumferential spacing less than 10mm, and data recording interval less than 3mm,  $3t$  axially by  $3t$  circumferentially is sufficient as a minimum. For the some thinner wall pipe,  $6t$  by  $6t$  can be recommended to compensate for any metal loss detection issues depending on UT ILI tool specification. However, for some pipeline configurations and ILI tool accuracies, assessments may not be conservative even with large interaction rules.

The use of the Level 2 Effective Area Method proves that it is largely insensitive to the application of an axial interaction rule, provided the interaction rule is large enough to capture the effective length of the predicted failure region. Based on recent studies,  $6t$  by  $6t$  is a recommended minimum interaction criterion. However, tools must have enough resolution to obtain a river bottom depth profile to be able to perform the iterative process of determining the effective length and depth. It is also recommended to validate the tool in order to use this more precise approach, however, including the POD and sizing, and probability of identification (POI). Using an Effective Area Method results in more accurate failure pressure predictions, but only when the ILI data provided are validated.

The studies listed previously use either a wall thickness based approach to interaction rules, or one which incorporates the size of the flaw into whether or not the features interact. By incorporating the sizing of the flaws as reported by ILI, the method becomes highly variable and difficult to implement. Additionally, if the ILI sizing of anomalies is not accurate, the interaction may not be conservative based on those results. Applying an interaction rule based on wall thickness



incorporates the concept of the bending moments and overall wall thinning more directly. Its ease of application is another advantage of applying interaction rules based solely on wall thickness.

The most commonly applied interaction rules used by the pipeline industry are based on an integer multiplier of wall thickness. Other industry standards and approaches from the USA, Canada and Great Britain are based on the size of the anomaly. The new size-based methods are well justified and documented and appear to be acceptable methods for interacting metal loss defects. However, there is no clear evidence to support the anomaly size methods have significant improvement over the wall thickness approach in reducing the conservatism and eliminating non-conservative errors. The anomaly size methods appear to be more difficult to apply to ILI data and are slow to be adopted. It would be advantageous to perform additional studies from in-ditch data collected by a high resolution measurement technique to compare the difference between methods that are based upon wall thickness versus the size of the anomaly reported by ILI. If a clear benefit can be established, then adoption would be justified.

The use of an interaction of  $6t$  axially by  $6t$  circumferentially is recommended overall due to its ease of application and supports the studies which recommend a larger interaction rule than the minimum suggested in ASME B31G without being overly conservative. This should be sufficiently large enough to capture the effective length for RSTRENG, but not overly large for B31G and modified B31G assessments that it creates excess conservatism. It may be beneficial to perform an interaction analysis burst pressure test of various actual corrosion morphologies due to the inherent inaccuracies of ILI data, particularly that of MFL technologies. FEA studies could be benchmarked by actual burst pressure tests to determine whether these studies can be supported. As technology improves or is validated, interaction criteria could be based more closely to what is recommended based on the FEA methods.

## CONCLUSIONS

1. Interaction rules help to determine a more accurate pressure at which a pipeline is predicted to fail in locations where there are multiple, closely spaced corrosion features. Location, wall thickness and anomaly sizes are the input variables for determining interacting areas of metal loss.
2. There are no standards or regulations which require the use of a specific interaction criterion, but federal regulations<sup>xviii,xix</sup> provide an acceptable minimum based on the B31G guideline. This approach can be non-conservative, and other assessment criteria are allowed.
3. Guidelines for interaction have been developed empirically and analytically. The empirical approach used burst tests, though the limited number of tests

makes it difficult to prove the method is robust. The smallest spacing was derived imperially at 3 wall thicknesses ( $3t$ ) in either direction. The analytical approach is based on derivations of material property strength relationships of remaining wall and simple corrosion morphologies. The analytical approaches presented varying degrees of conservatism with one specifying spacing that exceeds  $20t$  for some pipe configurations.

4. In-line inspections (ILI) have inherent capabilities and limitations, and performance should be validated prior to utilizing data from these inspections for integrity decisions. Poor probability of detection can lead to missed anomalies and a non-conservative failure pressure calculation. There are additional limitations to be aware of according to respective technologies but these limitations can be compensated for by the use of interaction rules.
  - Axial magnetic flux leakage (MFL) technology works well for isolated corrosion anomalies but reduced capability can be experienced when sizing specific anomalies in wide areas of corrosion and detecting all corrosion anomalies that may interact. Axially long, circumferentially narrow anomalies are particularly hard to assess. Circumferential blooming and axial shadowing associated with MFL analysis can influence interpretation of interaction.
  - Circumferential MFL – Circumferential MFL was designed to better assess the size of axially long, circumferentially narrow anomalies, but has less sizing accuracy for other corrosion morphologies such as corrosion pits and patches. The blooming and shadowing effects are similar to axial MFL, however the blooming is in the axial direction.
  - Other MFL approaches – To address the limitations of axial and circumferential MFL, ILI tools with tri-axial sensors or multiple magnetizers have been introduced. While these implementations have the potential reduce conservatism of interaction rules, no thorough assessment of these technologies was found in literature.
  - Ultrasonic technology (UT) specifications are in absolute distances, not percentage of wall thickness. These tools are more effective and provide more accurate results in thicker pipes greater than 12 mm (0.473 inches) and wide area corrosion. This technology is rarely used within natural gas pipelines because of the need for liquid coupling. The vendor's specification should be reviewed in detail when pitting corrosion is expected (review minimum pit size), the wall-

thickness is less than 0.25 inch (review detection threshold) or the wall-thickness is greater than 0.8 inch (review maximum wall thickness).

5. For application of B31G and Modified B31G failure pressure assessments, an interaction rule of at least six times the wall thickness (6t) axially by 6t circumferentially is recommended for use with MFL ILI data due to its ease of application and to support a larger interaction rule than the minimum suggested in ASME B31G without being overly conservative. When ILI provides a river bottom profile using successive boxes for that profile, RSTRENG or EAA may be performed using the same interaction rule.
6. Interaction criteria for UT ILI data is a function of tool capability and wall thickness. The key point is that the depth specification for UT tools is in units of length and not percentage of wall thickness like MFL specifications; therefore, the accuracy of UT tools as a function of percentage of wall thickness improves as the wall thickness increases. The interaction rules for UT tools can be as small as 3t axially by 3t circumferentially which corresponds with what is recommended within B31G. However, for some pipeline configurations and ILI tool accuracies, assessments may not be conservative even with large interaction rules.
7. With validation according to API 1163 providing ILI results within tool specification for both probability of detection of shallow metal loss and sizing accuracy of individual pits that are linked together to make a depth profile, an Effective Area failure pressure assessment may be used. Effective Area Assessments (EAA) are largely insensitive to errors when the interaction criteria are larger than the distance between defects, as the anomaly will be predicted to fail only at a certain effective length. It is recommended to apply a 6t by 6t interaction rule at minimum for EAA.

## REFERENCES

- <sup>i</sup> Kiefner & Associates, Inc. October 2006. *Validity of Standard Defect Assessment Methods for the Alliance Pipeline Operating at 80% of SMYS*. PHMSA Gas Transmission Integrity Management: Key Documents.
- <sup>ii</sup> Li, Yanping, et. al. 2017. *Evaluating ILI Tool Performance Using Validation Process*. 29<sup>th</sup> International Pipeline Pigging & Integrity Management Conference. Houston, TX.
- <sup>iii</sup> Nestleroth, J.B. and Bubenik, T. A., February 1999. Magnetic Flux Leakage (MFL) Technology for Natural Gas Pipeline Inspection, Battelle, Report Number GRI-00/0180 to the Gas Research Institute.
- <sup>iv</sup> ASME B31G-2012. *American National Standard. Manual for Determining the Remaining Strength of Corroded Pipelines: a*

*Supplement to ASME B31 Code for Pressure Piping*. Revision of ANSI/ASME B31G-1984. ASME. New York.

<sup>v</sup> Pipeline Operators Forum. 2016. *Specifications and requirements for in-line inspection of pipeline – Version 2016*. Pipeline Operators Forum – [www.pipelineoperators.org](http://www.pipelineoperators.org).

<sup>vi</sup> DNV-GL. May 2017. *DNVGL-RP-F101*. Retrieved August 7, 2017, from Recommended Practice Corroded Pipelines: <http://rules.dnvgl.com/docs/pdf/dnvgl/RP/2017-05/DNVGL-RP-F101.pdf>

<sup>vii</sup> CSA-Z662-2015. *Oil and gas pipeline systems*. CSA Group. Toronto, Ontario, Canada.

<sup>viii</sup> BS 7910:2005. *Guide on methods for assessing the acceptability of flaws in metallic structures*. British Standards Institution.

<sup>ix</sup> API RP 579-1/ASME FFS-1. 2016. *Fitness-For-Service*, Third Edition. American Petroleum Institute, Washington, DC.

<sup>x</sup> ASME B31.4-2016. 2016. *Pipeline Transportation Systems for Liquids and Slurries*. ASME Code for Pressure Piping, B31. The American Society of Mechanical Engineers (ASME). New York.

<sup>xi</sup> Kiefner J.F. *Fracture initiation*. In: 4th symposium on line pipe research, paper G, American Gas Association (AGA). Pipeline Research Council International; November 1969. PRCI Report, Catalog No. L30075.

<sup>xii</sup> ASME B31.4-2016. 2016. *Pipeline Transportation Systems for Liquids and Slurries*. ASME Code for Pressure Piping, B31. The American Society of Mechanical Engineers (ASME). New York.

<sup>xiii</sup> Coulson, K.E.W., Worthingham, R.G. April 1990. *Pipe Corrosion-Conclusion New Guidelines Promise More Accurate Damage Assessment*. Oil and Gas Journal Article Vol 88 Issue 16, Pages 41-44.

<sup>xiv</sup> Chauhan, V., Grant, R. October 2002. *Improved Methods for the Assessment of the Remaining Strength of Corroded Pipelines (Phase 4)*. Pipeline Research Council International, Inc.

<sup>xv</sup> Cunha, S.B. 2008. *An Analytical Interaction Rule for Corrosion Flaws*. 7<sup>th</sup> International Pipeline Conference. Alberta, Canada.

<sup>xvi</sup> Chandra, B., Mondal, B.C., Dhar, A.S. 2016. *Burst Pressure Assessment for Pipelines with Multiple Corrosion Defects*. Resilient Infrastructure. London.

<sup>xvii</sup> Smart, L., McNealy, R., Haines, H. September 2012. *Corrosion Metal Loss Interaction from In-line Inspection and How it Can Affect the Calculated Failure Pressure*. IPC2012-90141. Alberta, ON, Canada.

<sup>xviii</sup> 49 Code of Federal Regulations (CFR) Section 192, Subpart O. *Transportation of Natural and Other Gas by Pipeline: Minimum Federal Safety Standards: Gas Transmission Pipeline Integrity Management*. Government Publishing Office.

<sup>xix</sup> 49 Code of Federal Regulations (CFR) Section 195.45. *Transportation of Hazardous Liquids by Pipeline: Pipeline Integrity Management in High Consequence Areas*. Government Publishing Office.